



CHASSIS MOUNT SERIES

DC Power Supply With Power Factor Correction and Battery Charging in 12 Volt DC Model

The ICT Chassis Mount Series is designed for global markets, and features universal power factor corrected AC input, high efficiency of 90%, ultra low FCC Class B emissions, and is designed to global regulatory certification standards. Extended range operating temperature with temperature controlled cooling fan and threaded mounting positions make the Chassis Mount Series ideal for demanding or enclosed location applications.

Output voltage is adjustable using the provided trim pot. The Chassis Mount Series also incorporates current-limited battery backup terminals for float charging a battery as a standard feature.



ELECTRICAL SPECIFICATIONS (All Models)

Input Voltage Range	100-265VAC
Frequency	50/60Hz
Power Factor	0.99 (typical, 120VAC input)
Efficiency (typical)	90% (typical, full load, 230VACb input)
Output Voltage	13.8 VDC (+/- 0.5%)
Line Regulation	< 0.1%
Load Regulation	< 0.2%
Output Ripple (typical)	< 25mV rms
Input Connector	3 Position Terminal Block
Output Connector	4 Position Terminal Block

OUTPUT CURRENT

Model No.	Output Voltage Range ^(a)	Continuous Output
ICT24012-20CM	12.0-15.5 VDC	20 Amps

(a) Trim pot adjustable

ENVIRONMENTAL

Operating Temperature Range	-30C to +60C (derate > 50C)
Cooling	Fan Cooled
Storage Temperature Range	-40C to +70C
Operating Environment	Indoor, Pollution Deg 2

MECHANICAL

Height	1.85 inches (47 mm)
Width	4.22 inches (107 mm)
Depth	7.97 inches (203 mm)
Mounting	4 Integrated PEM Nuts #6-32
Grounding	6-32 stud located near input connector
Weight	2.05 lbs. (0.93kg)

REGULATORY

CSA/UL 60950-1, FCC Part 15/B, EN60950-1, EN61000-3-2, EN55022, EN55024

PROTECTION FEATURES

- Input fuse to protect against AC input over current faults
- Battery fuse to protect against reverse battery connection or output circuit fault
- Over temperature shutdown
- Over voltage protection shuts down output automatically
- AC input under-voltage shutdown with automatic restart
- Current limited battery float charge to prevent battery damage
- Constant-current control of output with foldback

OUTLINE DRAWING

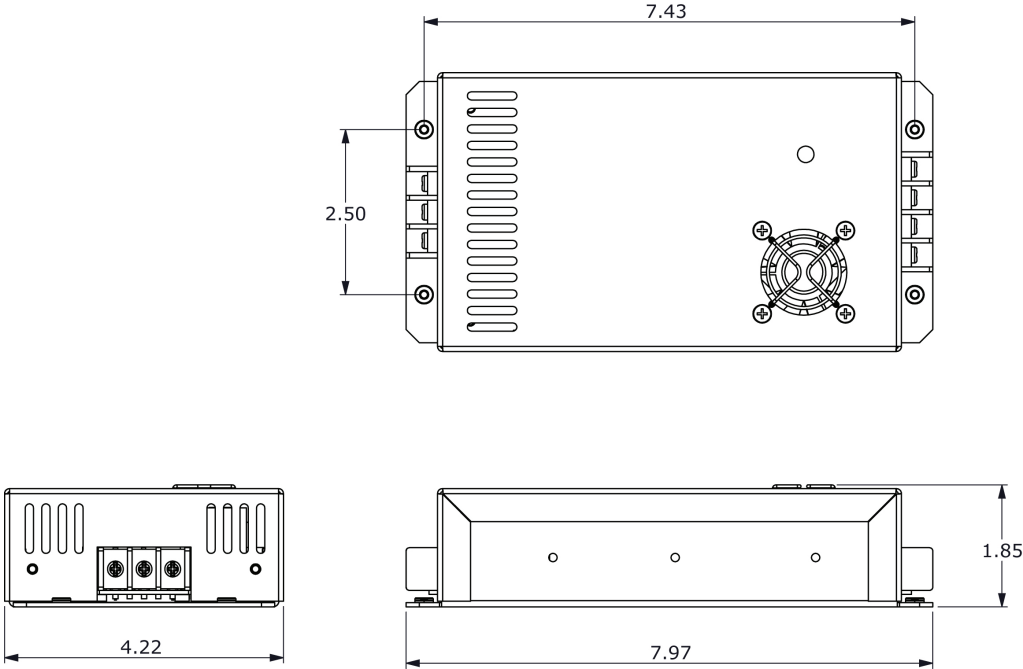

ORDERING INFORMATION

Description	Model Number
Chassis Mount Series DC Power Supply, 100-265VAC, 50/60Hz AC input, 20 Amp Continuous Output, 13.8 Volt DC	ICT24012-20CM

TYPICAL APPLICATIONS

The ICT Chassis Mount Series is ideal for mounting in enclosures, on sub-racks, or on other equipment. With high efficiency, a broad operating temperature range, adjustable output voltage, multiple protection features, standard battery backup current limited charging output, and integrated PEM mounting, the Chassis Series will power radios, repeaters, SCADA equipment, and other DC equipment while float charging a backup battery and providing DC UPS functionality for critical loads.

